

# Double pitch chains

---

Double pitch chains are a cost-effective solution for applications with lower speed and power transmission demands.



# Double pitch chains

Double pitch chains meet the same dimensions and specifications as the ISO 606 European and American standard chains, except for the pitch, which measures exactly twice their standard counterparts.

The longer pitch represents an extremely cost effective solution for applications where large centre distances exist and speed and power transmission demands are lower. The double pitch makes it possible to fit the rollers, and as a result, friction and tensile stress within the chain are greatly minimized for many applications.

These chains are also a lighter and economical option thanks to the reduction of material, although they are built with the same quality and accuracy as the single-pitch equivalents.

Conveyor type with straight side plates and transmission type can be produced. American standard chains include versions with smaller or larger rollers. Additionally, they can be provided in normal plate or thicker plate versions.

## SERVICES

Many products available from stock.

Corrosion resistant versions available (delta tone, stainless steel).

Special chains on request (for example, rollers with a larger diameter).

Matched pairs on request for chains working in parallel.

Chains in any length.

## HIGHLIGHTS

- ✓ Dimensions according to ISO 1275.
- ✓ Higher fatigue strength due to optimized press fit of pin and outer plate.
- ✓ Higher tensile strength due to optimized plate strength.
- ✓ Tensile strength can be reduced up to 20% if cranked links are fitted.
- ✓ Higher wear resistance.
- ✓ Minimum elongation due to wear and a long service life.
- ✓ Maximum rotating speed on the small sprocket: 500 r.p.m.

## Double pitch chains - ISO 1275 (DIN 8181)

### ISO SERIES

DIN/ ISO No.	Material	Pitch	Roller diameter	Width between Plates	Pin diameter	Pin length		Inner Plate height	Plate thickness	Minimum Tensile Strength	Weight per meter
		P mm	d1 max mm	b1 max mm	d2 max mm	L max mm	Lc max mm	h2 max mm	t/T max mm	Q min KN	q kg/m
208B	CS, DT, SS	25,40	8,51	7,75	4,45	16,70	18,20	11,80	1,60	18,00	0,45
210B	CS, DT, SS	31,75	10,16	9,65	5,08	19,50	20,90	14,70	1,70	22,40	0,65
212B	CS, DT, SS	38,10	12,07	1,68	5,72	22,50	25,20	16,00	1,85	29,00	0,76
216B	CS, DT, SS	50,80	15,88	17,02	8,28	36,10	39,10	21,00	4,15/3,1	60,00	1,75
220B	CS, DT, SS	63,50	19,05	19,56	10,19	41,30	45,00	26,40	4,5/3,5	95,00	2,62
224B	CS, DT, SS	76,20	25,40	25,40	14,63	53,40	57,80	33,20	6,0/4,8	160,00	4,70
228B	CS, DT, SS	88,90	27,94	30,99	15,90	65,10	69,50	36,70	7,5/6,0	200,00	6,23
232B	CS, DT, SS	101,60	29,21	30,99	17,81	66,00	71,00	42,00	7,0/6,0	250,00	6,72

### ASA SERIES

DIN/ ISO No.	ANSI No.	Material	Pitch	Roller diameter	Width between Plates	Pin diameter	Pin length		Inner Plate height	Plate thickness	Minimum Tensile Strength	Weight per meter
			P mm	d1 max mm	b1 max mm	d2 max mm	L max mm	Lc max mm	h2 max mm	t/T max mm	Q min KN	q kg/m
208A	2040	CS, DT, SS	25,40	7,95	7,85	3,96	16,60	17,80	12,00	1,50	14,10	0,42
210A	2050	CS, DT, SS	31,75	10,16	9,40	5,08	20,70	22,20	15,00	2,03	22,20	0,73
212A	2060	CS, DT, SS	38,10	11,91	12,57	5,94	25,90	27,70	18,00	2,42	31,80	1,02
216A	2080	CS, DT, SS	50,80	15,88	15,75	7,92	32,70	36,50	24,00	3,25	56,70	1,70
216A H	2080 H	CS, DT, SS	50,80	15,88	15,75	7,92	36,20	39,40	24,00	4,00	56,70	2,17
220A	2100	CS, DT, SS	63,50	19,05	18,90	9,53	40,40	44,70	30,00	4,00	88,50	2,55
224A	2120	CS, DT, SS	76,20	22,23	25,22	11,10	50,30	54,30	35,70	4,80	127,00	4,06

CS CARBON STEEL  
DT DELTA-TONE  
SS STAINLESS STEEL

# Double pitch chains

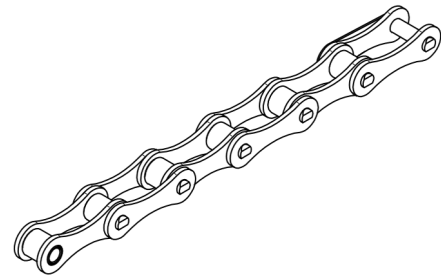
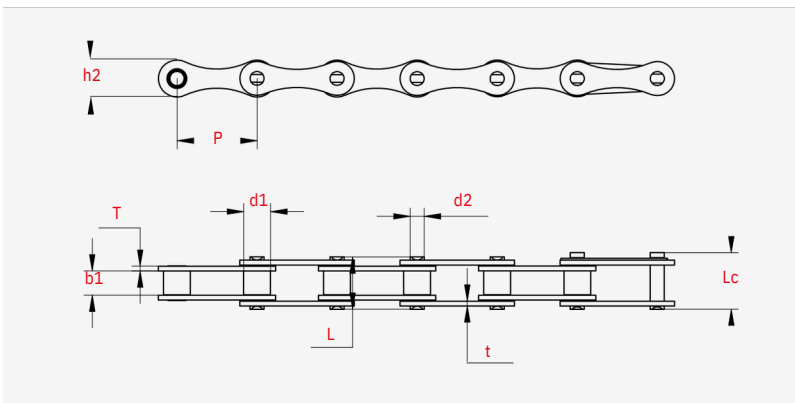

## Double pitch chains - ISO 1275 - Straight plate

### ASA STANDARD SERIES

DIN/ ISO No.	ANSI No.	Material	Pitch P mm	Roller diameter d1 max mm	Width between Plates b1 max mm	Pin diameter d2 max mm	Pin length		Inner Plate height h2 max mm	Plate thickness t/T max mm	Minimum Tensile Strength Q min KN	Weight per meter q kg/m
C208A	C2040	CS, DT, SS	25,40	7,95	7,85	3,96	16,60	17,80	12,00	1,50	14,10	0,50
C210A	C2050	CS, DT, SS	31,75	10,16	9,40	5,08	20,70	22,20	15,00	2,03	22,20	0,78
C212A	C2060	CS, DT, SS	38,10	11,91	12,57	5,94	25,90	27,70	18,00	2,42	31,80	1,12
C216A	C2080	CS, DT, SS	50,80	15,88	15,75	7,92	32,70	36,50	24,00	3,25	56,70	2,08
C220A	C2100	CS, DT, SS	63,50	19,05	18,90	9,53	40,40	44,70	30,00	4,00	88,50	3,01
C224A	C2120	CS, DT, SS	76,20	22,23	25,22	11,10	50,30	54,30	35,70	4,80	127,00	4,66
C232A	C2160	CS, DT, SS	101,60	28,58	31,75	14,27	64,80	69,60	47,80	6,40	226,80	8,15

### ASA HEAVY SERIES

DIN/ ISO No.	ANSI No.	Material	Pitch P mm	Roller diameter d1 max mm	Width between Plates b1 max mm	Pin diameter d2 max mm	Pin length		Inner Plate height h2 max mm	Plate thickness t/T max mm	Minimum Tensile Strength Q min KN	Weight per meter q kg/m
C208A H	C2040 H	CS, DT, SS	25,40	7,95	7,85	3,96	18,80	19,90	12,00	2,03	14,10	0,65
C210A H	C2050 H	CS, DT, SS	31,75	10,16	9,40	5,08	22,10	23,50	15,00	2,42	22,20	0,96
C212A H	C2060 H	CS, DT, SS	38,10	11,91	2,57	5,94	29,20	31,60	18,00	3,25	31,80	1,44
C216A H	C2080 H	CS, DT, SS	50,80	15,88	15,75	7,92	36,20	39,40	24,00	4,00	56,70	2,54
C220A H	C2100 H	CS, DT, SS	63,50	19,05	18,90	9,53	43,60	46,90	30,00	4,80	88,50	3,56
C224A H	C2021 H	CS, DT, SS	76,20	22,23	25,22	11,10	53,50	57,50	35,70	5,60	127,00	5,26
C232A H	C2160 H	CS, DT, SS	101,60	28,58	31,75	14,27	68,20	73,00	47,80	7,20	226,8	9,06

CS CARBON STEEL  
DT DELTA-TONE  
SS STAINLESS STEEL

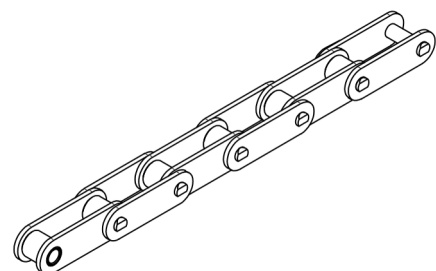
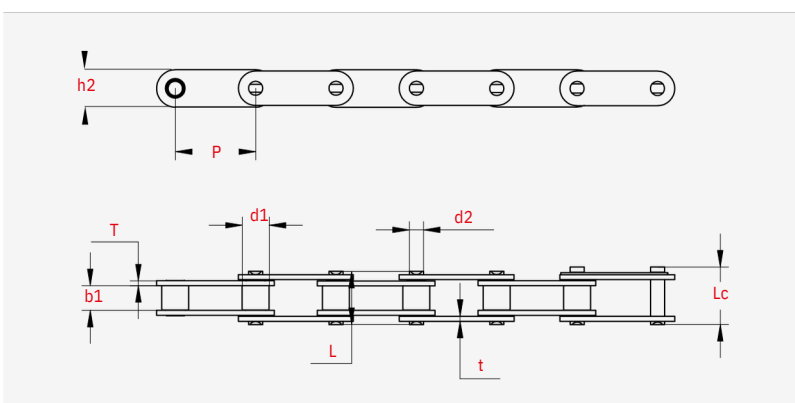

# Double pitch chains

Double pitch chains - ISO 1275 - Straight plate - Large rollers

## ASA STANDARD SERIES

DIN/ ISO No.	ANSI No.	Material	Pitch	Roller diameter	Width between Plates		Pin diameter		Pin length		Inner Plate height	Plate thickness	Minimum Tensile Strength	Weight per meter
			P mm	d1 max mm	b1 max mm	d2 max mm	L max mm	Lc max mm	h2 max mm	t/T max mm	Q min KN	q kg/m		
C208AL	C2042	CS, DT, SS	25,40	15,88	7,85	3,96	16,60	17,80	12,00	1,50	14,10	0,84		
C210AL	C2052	CS, DT, SS	31,75	19,05	9,40	5,08	20,70	22,20	15,00	2,03	22,20	1,27		
C212AL	C2062	CS, DT, SS	38,10	22,23	12,57	5,94	25,90	27,70	18,00	2,42	31,80	1,61		
C216AL	C2082	CS, DT, SS	50,80	28,58	15,75	7,92	32,70	36,50	24,00	3,25	56,70	3,12		
C220AL	C2102	CS, DT, SS	63,50	39,67	18,90	9,53	40,40	44,70	30,00	4,00	88,50	4,83		
C224AL	C2122	CS, DT, SS	76,20	44,45	25,22	11,10	50,30	54,30	35,70	4,80	127,00	7,66		

## ASA HEAVY SERIES

DIN/ ISO No.	ANSI No.	Material	Pitch	Roller diameter	Width between Plates		Pin diameter		Pin length		Inner Plate height	Plate thickness	Minimum Tensile Strength	Weight per meter
			P mm	d1 max mm	b1 max mm	d2 max mm	L max mm	Lc max mm	h2 max mm	t/T max mm	Q min KN	q kg/m		
C208A HL	C2042 H	CS, DT, SS	25,40	15,88	7,85	3,96	18,80	19,90	12,00	2,03	14,10	0,99		
C212A HL	C2062 H	CS, DT, SS	38,10	22,23	12,57	5,94	29,20	31,60	18,00	3,25	22,20	2,07		
C216A HL	C2082 H	CS, DT, SS	50,80	28,58	15,75	7,92	36,20	39,40	24,00	4,00	31,80	3,58		
C220A HL	C2102 H	CS, DT, SS	63,50	39,67	18,90	9,53	43,60	46,90	30,00	4,80	57,70	5,38		
C224A HL	C2122 H	CS, DT, SS	76,20	44,45	25,22	11,10	53,50	57,50	35,70	5,60	88,50	8,26		
C232A HL	C2162 H	CS, DT, SS	101,60	57,15	31,75	14,27	68,20	73,00	47,80	7,20	127,00	12,77		

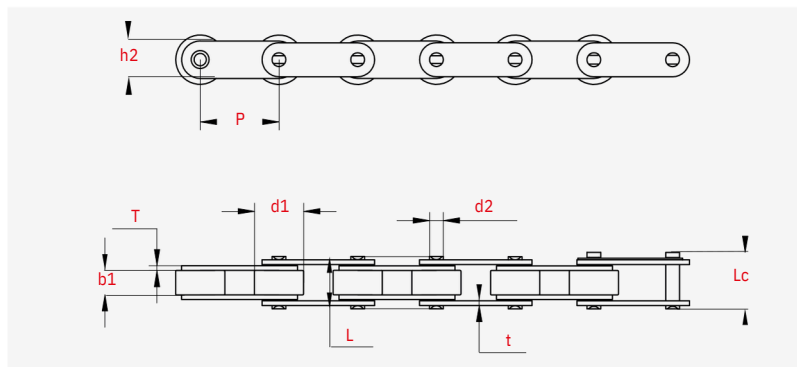

CS CARBON STEEL  
DT DELTA-TONE  
SS STAINLESS STEEL

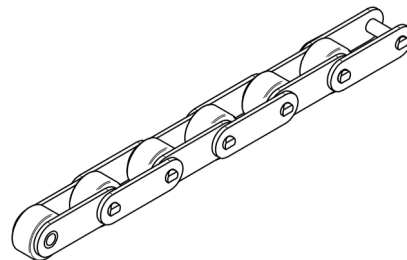





[www.iris-chains.com](http://www.iris-chains.com)

SINCE  
1935

Polígono Ind. Erisono nº 1  
20600 Eibar (Guipuzcoa) España  
T +34 943 120 550  
[iris@iris-chains.com](mailto:iris@iris-chains.com)