

Hollow pin chains

Hollow pin chains provide great design versatility.



Hollow pin chains

Hollow pin chains provide great design versatility for conveying applications, and make it possible to insert cross roads into any link without disassembling the chain. These chains are used in light handling, small conveyors, usually using two parallel chains.

IRIS manufactures hollow pin chains in American and European series, single and double pitch, with and without rollers, and with or without bush. The double pitch series is supplied either rollerless or with carrier rollers. Variants purposed for conveyors are also supplied.

Nickel-plated, Delta Tone, and Stainless Steel versions are also available.

Rollerless hollow pin chain

ISO DIN SERIES

DIN/ISO No.	Material	Pitch	Bush diameter	width between plates	Pin diameter		Inner Plate depth	Plate thickness	Ultimate Tensile strength	Weight per meter
		P mm	d1 max mm	b1 min mm	d2 max mm	d3 min mm	h2 max mm	t/T max mm	Q min KN	q kg/m
08B	CS,DT,SS	12.7	8.51	7.75	6,37	4,5	11,8	1,5	59,4	0,7
08B	CS,DT,SS	12.7	8.51	7.75	6,37	4,5	11,8	1,5	44	0,7
10B	CS,DT,SS	15.88	10.16	9.65	7,2	5	15	1,6	63,8	0,9
12B	CS,DT,SS	19.05	12.07	11.70	8,22	5,75	16,5	1,85	81,4	1,1
12B	CS,DT,SS	19.05	12.07	11.70	8,22	5,75	16,5	1,85	81,4	1,1

Rollerless hollow pin chain

ANSI SERIES

DIN/ISO No.	ANSI No.	Material	Pitch	Bush diameter	width between plates	Pin diameter		Inner Plate depth	Plate thickness	Ultimate Tensile strength	Weight per meter
			P mm	d1 max mm	b1 min mm	d2 max mm	d3 min mm	h2 max mm	t/T max mm	Q min KN	q kg/m
08A-1	40	CS,DT,SS	12.7	7,95	7,85	5,63	4	12	1,5	10,64	0,36
10A-1	50	CS,DT,SS	15.88	10,16	9,4	7,03	5,15	15,09	2,03	19,36	0,58
12A-1	60	CS,DT,SS	19.05	11,91	12,7	8,31	6	18	2,42	26,13	0,85
16A-1	80	CS,DT,SS	25.4	15,88	15,75	11,4	8,05	24	3,25	47,52	1,6

CS CARBON STEEL
 DT DELTA-TONE
 NP NICKELLED PLATED
 SS STAINLESS STEEL

SERVICES

Many references available in stock.

Corrosion-resistant versions available.

Specific product on request.

Matched pairs on request for chains working in parallel.

Chains of any length.

Technical assistance.

Hollow pin roller chains - Fixed bush type

ISO SERIES

DIN/ISO No.	Material	Pitch	Bush diameter	width between plates	Pin diameter		Pin length		Inner Plate depth	Plate thickness	Ultimate Tensile strength	Weight per meter	Breaking load Stainless steel
		P mm	d1 max mm	b1 min mm	d2 max mm	d3 min mm	L max mm	Lc max mm	h2 max mm	t/T max mm	Q min KN/lbf	q kg/m	Q0 KN
08B-1 HP	CS, NP, DT, SS	12,70	8,51	7,75	6,55	4,50	16,40	17,60	11,8	1,60	11,1	0,56	12,1
10B-1 HP	CS, NP, DT, SS	15,875	10,16	9,65	7,02	5,13	19,50	20,05	14,70	1,70	10,00	0,86	11,50
12B-1 HP	CS, NP, DT, SS	19,05	12,07	11,7	8,22	5,75	24,5	24,9	16,5	1,85/2,40	16,00	1,14	18
16B-1 HP	CS, NP, DT, SS	25,40	15,88	17,02	11,50	8,20	35,30	37,00	23,2	4,00/3,10	49,00	2,26	52,2
08B-1 HP D3=4	CS, NP, DT, SS	12,70	8,51	7,75	6,3	4,50	16,8	18	12	1,60	9,60	0,62	10,60
10B-1 HP D3=4	CS, NP, DT, SS	15,875	10,16	9,5	7,2	5,00	19,8	21,3	14	2,03/1,60	12,50	0,82	14,00
12B-1 HP D3=6	CS, NP, DT, SS	19,05	12,07	11,68	8,09	6,00	22,7	23,9	16,1	1,85	14,00	0,82	16,00

ASA SERIES

DIN/ISO No.	ANSI No.	Material	Pitch	Bush diameter	width between plates	Pin diameter		Pin length		Inner Plate depth	Plate thickness	Ultimate Tensile strength	Weight per meter	Breaking load Stainless steel
			P mm	d1 max mm	b1 min mm	d2 max mm	d3 min mm	L max mm	Lc max mm	h2 max mm	t/T max mm	Q min KN	q kg/m	Q min KN
08A-1 HP	40 HP	CS, DT, SS	12,70	7,95	7,85	5,63	4,00	16,50	17,60	12,00	1,50	11,00	0,54	12,2
10A-1 HP	50 HP	CS, DT, SS	15,875	10,16	9,40	7,03	5,15	20,50	21,70	15,09	2,03	20,00	0,91	22,6
12A-1 HP	60 HP	CS, DT, SS	19,05	11,91	12,70	8,31	6,00	25,80	26,80	18,00	2,42	24,00	1,29	26,9
16A-1 HP	80 HP	CS, DT, SS	25,40	15,88	15,75	11,40	8,05	32,50	33,80	24,00	3,25	50,00	2,26	52

- CS CARBON STEEL
- DT DELTA-TONE
- NP NICKELLED PLATED
- SS STAINLESS STEEL

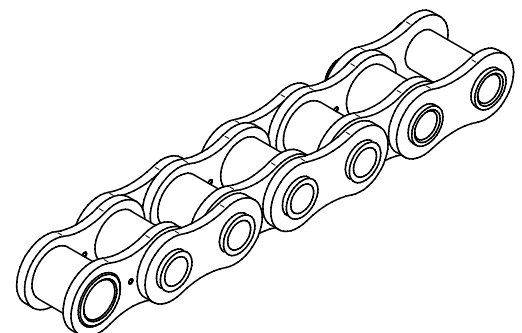
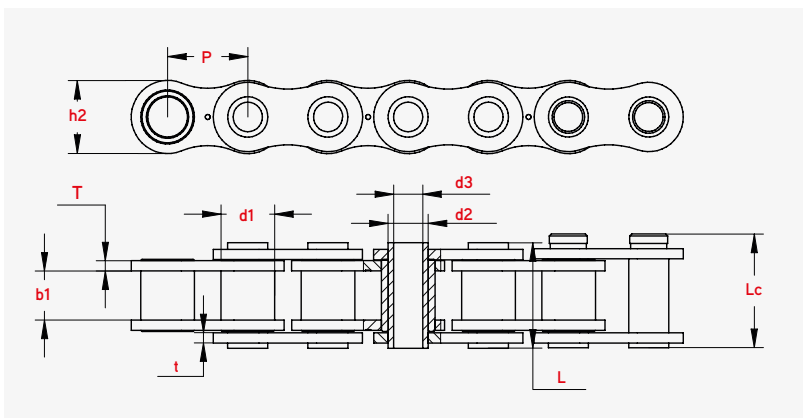

Double pitch hollow pin chains

Double pitch hollow pin chains - Straight plates - Fixed bush type

ASA SERIES

ASA SERIES			Pitch	Bush diameter	width between plates	Pin diameter		Pin length		Inner Plate depth	Plate thickness	Ultimate Tensile strength	Weight per meter	Breaking load Stainless steel
DIN/ISO No.	ANSI No.	Material	P mm	d1 max mm	b1 min mm	d2 max mm	d3 min mm	L max mm	Lc max mm	h2 max mm	t/T max mm	Q min KN/lbf	q kg/m	Q0 min KN
C208A HP	C2040 HP	CS, DT, SS	25,40	7,95	7,85	5,63	4,00	16,50	17,60	12,00	1,50	11,00	0,46	12,6
C210A HP	C2050 HP	CS, DT, SS	31,75	10,16	9,40	7,03	5,10	20,70	21,90	15,09	2,03	20,00	0,76	22,8
C212A HP	C2060 HP	CS, DT, SS	38,10	11,91	12,70	8,31	6,00	25,80	26,80	17,00	2,42	24,00	1,02	27,1
C216A HP	C2080 HP	CS, DT, SS	50,80	15,88	15,75	11,40	8,05	32,50	33,80	24,00	3,25	50,00	1,81	52

CS CARBON STEEL
DT DELTA-TONE
SS STAINLESS STEEL

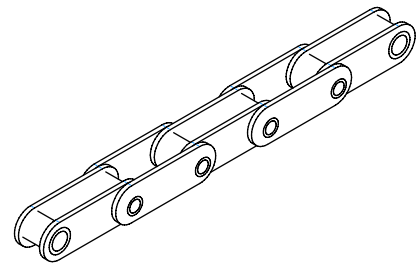
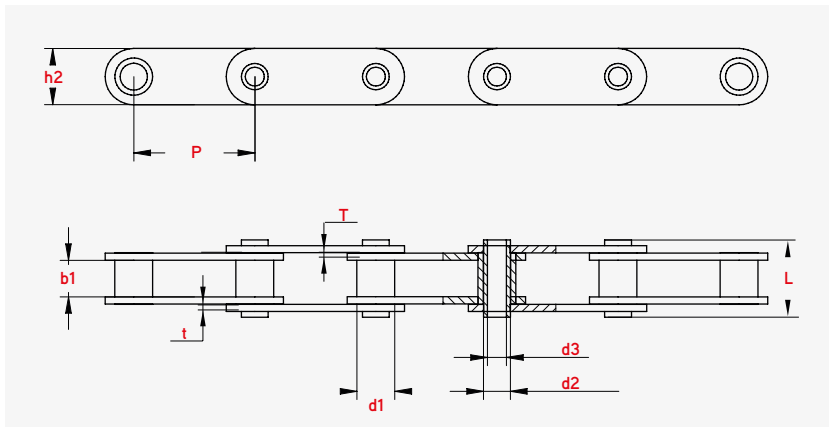

Double pitch hollow pin chains - Straight plates - Oversize roller type

ASA SERIES

DIN/ISO No.	ANSI No.	Material	Pitch	Bush diameter	width between plates	Pin diameter		Pin length		Inner Plate depth	Plate thickness	Ultimate Tensile strength	Weight per meter	Breaking load Stainless steel
			P mm	d1 max mm	b1 min mm	d2 max mm	d3 min mm	L max mm	Lc max mm	h2 max mm	t/T max mm	Q min KN/lbf	q kg/m	Q min KN
C208AL HP	C2042 HP	CS,DT,SS	25,40	15,88	7,85	5,63	4,00	16,50	17,60	12,00	1,50	11,00	0,78	12,6
C210AL HP	C2052 HP	CS,DT,SS	31,75	19,05	9,53	7,22	5,12	20,50	21,80	15,00	2,03	20,40	1,25	22,8
C212AL HP	C2062 HP	CS,DT,SS	38,10	22,23	12,70	8,31	6,00	25,80	26,80	17,00	2,42	24,00	1,72	27,1
C216AL HP	C2082 HP	CS,DT,SS	50,80	28,58	15,75	11,40	8,05	32,40	33,80	24,00	3,25	50,00	2,82	52
C208ALH HP	C2042H HP	CS,DT,SS	25,40	15,88	7,85	5,63	4,00	18,80	19,90	12,00	2,03	11,00	0,95	13,2
C210ALH HP	C2052H HP	CS,DT,SS	31,75	19,05	9,53	7,22	5,12	22,10	23,40	15,00	2,42	20,40	1,44	23,5
C212ALH HP	C2062H HP	CS,DT,SS	38,10	22,23	12,70	8,31	6,00	29,20	30,20	17,00	3,25	24,00	1,99	27,60
C216ALH HP	C2082H HP	CS,DT,SS	50,80	28,58	15,75	11,40	8,05	35,70	37,00	24,00	4,00	50,00	3,34	56,5
C210ALH HP T1	C2052H HP T1	CS,DT,SS	31,75	19,05	9,40	7,03	5,12	20,00	21,50	15,30	1,85	15,00	1,21	17,3

CS CARBON STEEL
DT DELTA-TONE
SS STAINLESS STEEL

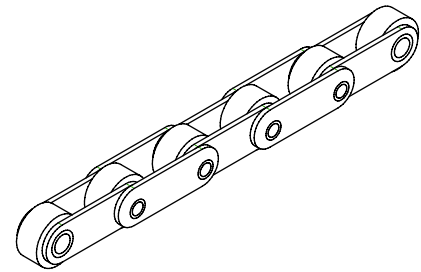
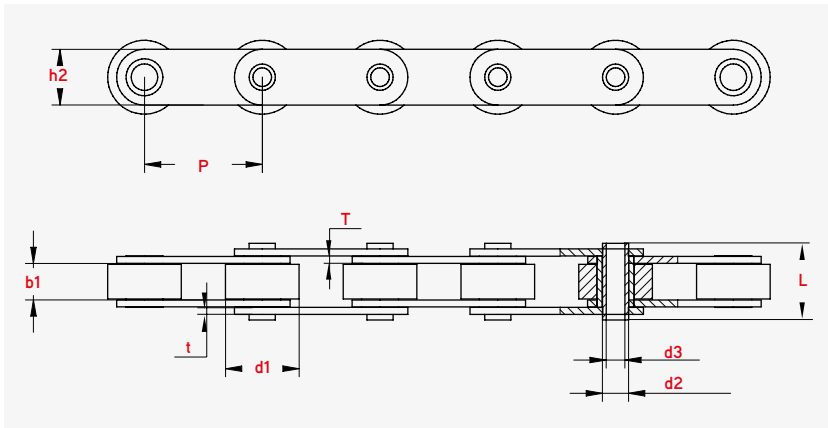

Hollow
pin chains

Conveyor hollow pin chains

IRIS supplies hollow pin chains that can be matched with the demands of a wide range of shuttle conveyor applications.

Stainless steel and delta-tone versions are also available for conveyors which must remain clean or when it is desirable to ease maintenance.

Conveyor hollow pin chains - Fixed bush type

DIN/ISO No.	Material	Pitch	Bush diameter	width between plates	Pin diameter		Pin length		Inner Plate depth	Plate thickness	Ultimate Tensile strength	Weight per meter
		P mm	d1 max mm	b1 min mm	d2 max mm	d3 min mm	L max mm	Lc max mm	h2 max mm	t/T max mm	Q min KN	q kg/m
P25.4 T1	CS, DT, SS	25,4	20,00	11,00	12,00	8,2	27	29	24	3	25	1,3
P24.4 T2	CS, DT, SS	25,4	15,88	17,02	6,05	4,2	28	30	14	2		
P35 T1	CS, DT, SS	35,0	20,00	16,00	14,00	10,2	32	34	26	3	23,5	2
P38.1 T1	CS, DT, SS	38,1	12,07	25,04	12,00	8,2	27	29	21	2,5		1,5
P41.75 T1	CS, DT, SS	41,75	17,00	20,50	11,00	8,3	36	40,7	22	3	27,00	

CS CARBON STEEL
DT DELTA-TONE
SS STAINLESS STEEL

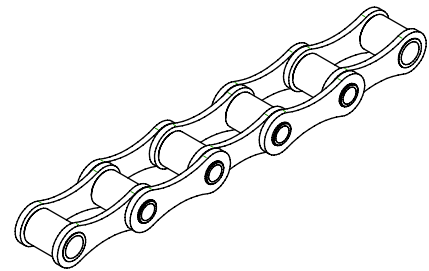
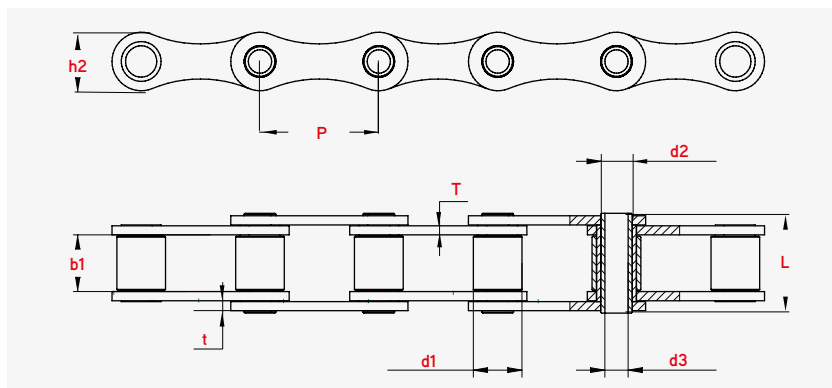

Conveyor hollow pin chains - Oversize roller type

DIN/ISO No.	Material	Pitch	Roller diameter	width between plates	Pin diameter		Pin length		Inner Plate depth	Plate thickness	Ultimate Tensile strength	Weight per meter
		P mm	d1 max mm	b1 min mm	d2 max mm	d3 min mm	L max mm	Lc max mm	h2 max mm	t/T max mm	Q min KN	q kg/m
P50 TB1	CS, DT	50	30	10	11,5	8,2	26,5	27,75	25,5	3	60,00	2,2
P50.8 T1	CS, DT, SS	50,8	30	10	11,5	8,2	26,5	27,75	25,5	3	60,00	2,1
P60 T1	CS, DT	60	30	10	11,5	8,2	26,5	27,75	26	3	60,00	1,5
P63 TB1	CS, DT	63	30	10	11,5	8,2	26,5	27,75	26	3	60,00	2,3
P100 TB6	CS, DT	100	30	10	11,5	8,2	26,5	27,75	25,5	3	60,00	1,5

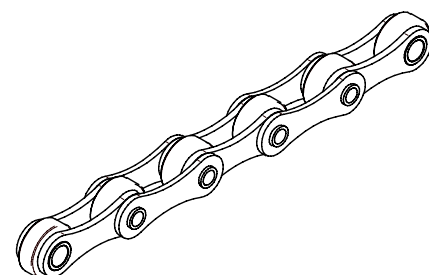
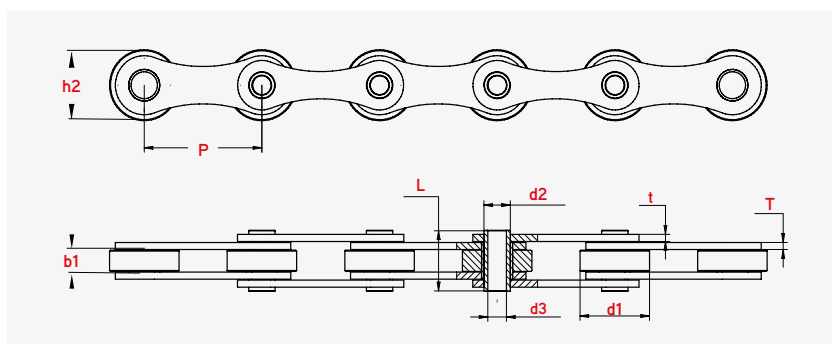

Conveyor hollow pin chains

Conveyor hollow pin chains - Straight plates - Oversize roller type

DIN/ISO No.	Material	Pitch	Roller diameter	width between plates	Pin diameter		Pin length		Inner Plate depth	Plate thickness	Ultimate Tensile strength	Weight per meter
		P mm	d1 max mm	b1 min mm	d2 max mm	d3 min mm	L max mm	Lc max mm	h2 max mm	t/T max mm	Q min KN	q kg/m
P50 TA1	CS, DT, SS	50	25	11,5	9	6,2	25	26,5	20	2,5	25,00	1,8
P50 TA2	CS, DT	50	31	15	14	10,2	31	32,5	25	3	35,00	3
P50 TA3	CS, DT, SS	50	31	15	14	10,2	35	36	25	4	40,00	3,6
P50 TA4	CS, DT, SS	50	17	22	12	8	41	43	25	3		
P50 TA5	CS, DT, SS	50	31	15	14	10,2	31	33	25	3		
P50 TA6	CS, DT, SS	50	31	15	14	10,2	31	33	25	3		
P63 TA1	CS, DT, SS	63	30	18	14	10,2	35	37	25	3		
P70 TA1	CS, DT, SS	70	25	14	16	12,2	35,5	37,5	30	4		
P70 TA2	CS, DT, SS	70	30	15	16	12,2	36,5	38,5	35	4		
P75 TA1	CS, DT, SS	75	31	15	14	10,2	35	36	25	4	40,00	3,1
P75 TA2	CS, DT	75	31	15	14	12,2	45	46	35	4	60,00	4,6
P75 TA3	CS, DT, SS	75	28	15,5	14	8,5	37	39	35	4		
P75 TA4	CS, DT, SS	75	20	22	14	10,2	41	43	30	3		
P80 TA1	CS, DT, SS	80	42*	24	16	10,2	45,5	47,5	30	4		
P100 TA1	CS, DT, SS	100	31	15	14	10,2	35	36	25	4	40,00	2,6
P100 TA2	CS, DT	100	31	15	14	12,2	45	46	35	4	60,00	4,4
P100 TA3	CS, DT, SS	100	30	32	18	14,2	62	64	40	6		
P100 TA4	CS, DT, SS	100	30	15	16	12,2	36,5	38,5	35	4		
P100 TA5	CS, DT, SS	100	40	25	25	20,2	52	54	50	5		
P102,5 TA1	CS, DT, SS	102,5	30	15	17	8,5	37	39	40	4		
P105 TA1	CS, DT, SS	105	30	15,5	20	14,5	38	40	40	4		
P125 TA1	CS, DT, SS	125	40	22	18	10,2	35	36	25	4	40,00	2,4
P125TA2	CS, DT	125	40	22	18	12,2	45	46	35	4	60,00	4,2
P150 TA1	CS, DT	150	40	22	18	10,2	35	36	25	4	40,00	2,3
P150 TA2	CS, DT	150	40	22	18	12,2	45	46	35	4	60,00	4

CS CARBON STEEL
DT DELTA-TONE
SS STAINLESS STEEL

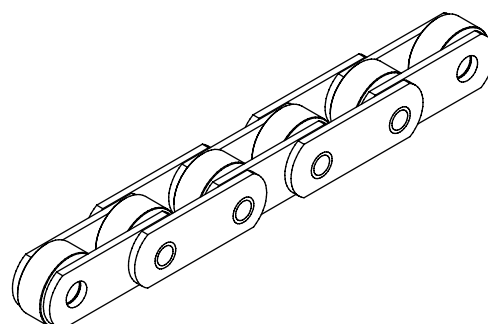
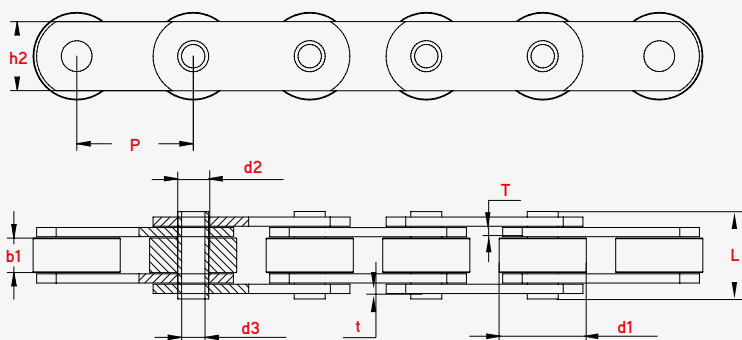



www.iris-chains.com

SINCE
1935

Polígono Ind. Erisono nº 1
20600 Eibar (Guipuzcoa) España

T +34 943 120 550
iris@iris-chains.com